

Rotating Telehandlers



Index

The Merlo Group	Page 4
Rotating telehandler range	Page 6
Merlo Technologies	
• Safety	Page 8
• Performance	Page 12
• Comfort	Page 14
• Efficiency	Page 16
Range	Page 18
Attachments and Movimatica	Page 24
Services	Page 24
Technical characteristics	Page 25







Merlo Headquarters

S. Defendente di Cervasca (CN)
Italy

Merlo facility with 350000 m² of covered area:

- A - Electrical component production
- B - Hydraulic component production
- C - Frame production
- D - Cab production
- E - Axle production
- F - Engine configuration
- G - Machine assembly



Merlo The technological leader in operating machines

Founded in Cuneo, Italy in 1964, Merlo is a family-run industrial group which designs, produces and markets a wide range of machinery under the Merlo and TreEmme brands.

People, innovation and sustainability are central to the Merlo brand. The Merlo Group is committed to respecting the environment while making the work of the operator (and everyone who is passionately dedicated to constantly improving the efficiency and performance of our products) more functional, safe and comfortable.

Our product portfolio consists of a complete range of telescopic handlers (both fixed and rotating), as well as self-loading concrete mixers (DBMs), TreEmme implement-holders for municipal and forestry use, and multi-purpose tracked Cingo transporters.

All products in the Merlo range are characterised by innovation, reliability and versatility. These pillars are the foundation of the Merlo Group, and continue to define Merlo's product range to this day.

Merlo S.p.A has always been synonymous with technological innovation in the world of telehandlers.



2021
Electric

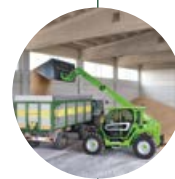

2012
Modular



2000
Multifarmer



1996
Turbofarmer



1991
Roto



1987
Panoramic



1981
SM



Rotating telehandler range

The highest productivity on the market

Great innovations are born from simple ideas, such as the one that radically changed the world of telehandlers in the early 1990s and led to the launch of the rotating telehandler range - the ROTO models. The idea was to include a rotating turret system that guaranteed the possibility of working 360° around the machine without having to reposition it, thus increasing productivity and safety for the operator.

Since 1991, when the first ROTO model was launched, this new concept of telehandler has continued to evolve up to the present day, taking the form of a complete range of rotating telehandlers, and becoming increasingly popular on a global scale, making the Merlo Group a leader in this segment of specialised machines which find applications in a wide range of contexts: from the construction world, to rental and sectors like industry, forestry and municipalities.

Cab:

Level II FOPS and ROPS certified, designed to maintain the maximum level of ergonomics while ensuring excellent protection for the operator. The 1010 mm width and the wide glass surface ensure unparalleled comfort and full visibility.

Hydraulic System:

Hydraulic system specifically sized to minimise manoeuvring times. Variable displacement (Load Sensing) hydraulic pump and Flow Sharing distributor, for maximum efficiency, excellent performance, and perfectly smooth operation.

User Interface:

In-cab display for viewing operational parameters. Ergonomic joystick controls with integrated travel-direction selector switch. Cursors and controls are designed to maximise ease of implementation.

Powertrain:

Hydrostatic transmission with permanent four-wheel drive, 75 to 170 HP engines and maximum speed of 40 km/h. Exclusive position of the side and longitudinal engine.

Suspension:

The only models on the market to offer active hydropneumatic suspension on the axles. For maximum safety and optimal driving comfort. This solution eliminates the pitching motion when taking curves, for greater stability.

Telescopic Boom:

Heights from 16 to 35 metres with load-bearing capacities from 4000 to 7000 kg. Exclusive design that ensures lightness, precision and durability. Implement-holder carriage equipped with hydraulic Tac-lock locking system, controllable from the cab.



Safety

Our Key Focus

Throughout the design of a Merlo, our main focus is always on operator safety. The cab structure, certified according to ISO 3449 FOPS and ISO 3471 ROPS standards, provides a class-leading level of protection for telehandler users. The FOPS protection grille is outside of the glass roof to improve headroom in the cab while protecting the structure of the machine and the windscreen. All Merlo models are equipped with a built-in safety system which monitors and manages safety-related parameters in real-time. Merlo telehandlers also feature an automatic parking brake which engages if the engine switches off. This avoids unintentional movements, enhancing machine safety when stationary.

Merlo Boom

The Merlo boom uses a double "C" profile in high-strength steel, with welds made along the neutral bending axis. Hydraulic hoses and electrical wires positioned inside the boom, utilising a **"cartridge" system**, are protected against any possible impacts and allow easy component extraction in case of required maintenance. The L-shaped runner blocks are made of composite material, maximising efficiency and reducing impact and wear on the sliding surfaces. The Merlo boom offers high accuracy with millimetric precision of movement control.



FOPS Protection

All Merlo telehandlers have a **metal structure above the glass roof on the outside of the cab** to comply fully with FOPS Level II standard, the most stringent certification level in protecting the operator from falling objects. The Merlo protection grid on top of the cab is moulded to reduce any impact on operator visibility, and ensures:

- Perfect comfort in the cab.
- Excellent visibility of the load.
- Maximum safety for the operator and cab components, including roof and upper windscreen wiper.
- The structure can be easily dismantled by the operator for thorough cleaning of the roof and windscreen.

Movement management

To ensure **maximum operating safety and ease of use**, in all contexts and using the different implements available, the rotating telehandlers can be optionally equipped with two capacitive joysticks combined with some sliders that allow hydraulic functions to be inhibited in order to prevent unintentional movements that could lead to incorrect use of the implement. For example, when working with a winch, it is possible to block the rotation of the carriage, allowing the operator to work at the right angles, in order to preserve the integrity of the implement rope.



Frame and turret

The machine's frame and turret are characterised by **small dimensions** compared to market standards, in order to minimise the machine's overall dimensions. In addition, on the outside of the frame, there is a unique belt made from a steel section. Designed to maximise the strength of the machine's structure, the underside of the machine is completely protected by steel sheets. This protects all components from possible impact while driving off-road. Finally, the turret is designed to minimise the overhang in relation to the frame and stabilisers.

Levelling

Rotating telehandlers can be equipped with a lateral and longitudinal levelling corrector. Thanks to this solution, by acting on a simple control in the cab, the customer can modify the machine frame transversal tilting, compensating for sloping terrain up to a maximum of 8% - approx. 5° and a longitudinal inclination up to a maximum of 4% - approx. 2,5°. In this way, it ensures a **perfectly vertical lifting of the load**, by limiting the risks of machine instability.



ASCS

Merlo's ASCS (Adaptive Stability Control System) prevents risk of the machine tipping over while handling a load.

The system regulates the speed and maximum degree of movement according to three operating parameters:

- Handled load - Kg of materials lifted
- Load position - reach, boom extension, turret rotation and carriage rotation
- Implement in use - **automatically recognised by special sensors.**

When the operational stability limit is reached, the system first reduces the speed of the arm, then stops movement completely. Independent control of each hydraulic movement allows for the identification of potentially unsafe movements, allowing only those which do not affect the stability, or which re-establish a safer position.

Display

The ASCS system is equipped as standard with a **10,1" colour display** with integrated sensor for automatic brightness adjustment according to external light conditions. In this way, a simple reading of the stability conditions is always ensured, updated in real time, according to the load being handled and the implement in use. The operator can always see at what point the safety system will be triggered. Once the system intervenes by blocking all movements, a pop-up message appears, showing the operator all movements and operations which are not detrimental to the stability of the machine. Finally, the inclinometer is shown to maximise the safe use of the machine.

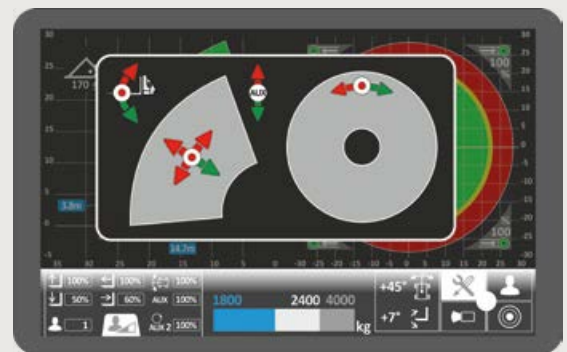

Working Area Setting

A special function, accessible via the display, allows the operator to **set working area restrictions**.

Adjustments can be made to vertical and horizontal movements (minimum and maximum height and extension), or to the relative movements of the boom (maximum and minimum lift angle, turret rotation angle and extension).

Adjustments are easy and precise, operating using the green thumb-wheel located near the joystick. This guarantees accurate adjustments of 0,1 metres while operating the boom. Angles can be adjusted to an accuracy of 1 degree. The working area settings **increase safety during repetitive work, particularly in confined spaces**, such as inside a warehouse.

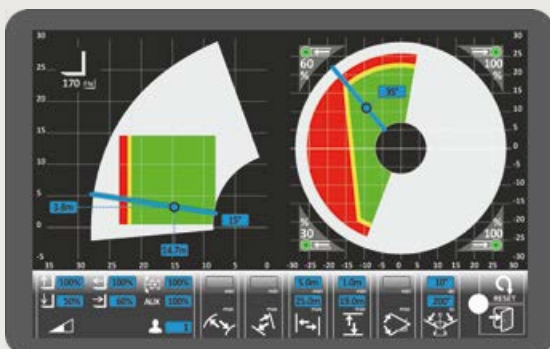

Movement Speed Setting

Merlo's ASCS system uses an in-cab display to customise the speed of individual movements of the boom and attachments in use. All of these parameters are controlled according to the needs of the operator as well and the requirements of the job. Up to nine different setups can be stored.

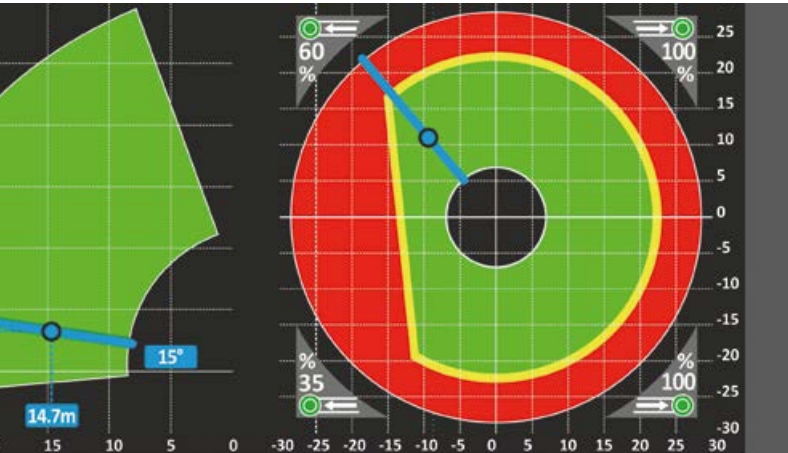
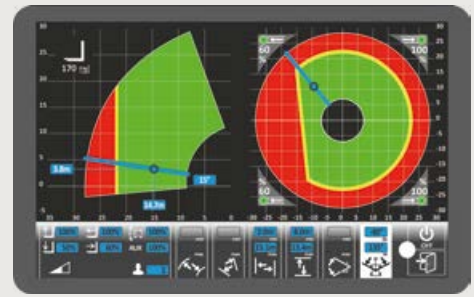

Work area

The ASCS display shows the maximum working area achievable with the load being handled. In the Plus configuration of the ASCS system, exploiting the possibility of positioning the stabilisers in any position, the working area will vary in accordance with the actual position of the stabilisers. The precise extension of each stabiliser is shown in the graph (value expressed in %). As the position of each stabiliser varies, the stability limit of the dedicated section will also vary proportionally.

Continuous Delivery

Models with the ASCS display are equipped with a system for regulating and delivering a constant flow of oil to attachments via the headstock. This allows for **oil flow to be precisely and specifically adjusted from zero to maximum flow rate** for each of the 4 auxiliary hydraulic outlets at the top of the boom. This solution is also available as an option for several other models.



Cameras

In combination with the 10,1" colour display of the ASCS, it is possible to equip the machine with front and rear camera. The rear camera is operated automatically upon engagement of the reverse gear. Images from the cameras are shown directly on the in-cab display.

In all cases, the camera can be activated manually from the ASCS menu.

Digital spirit level

To simplify machine commissioning operations by facilitating the correct configuration of the stabilisers, the ASCS allows the frame levelling condition to be displayed in real time at the press of a button. Whether operating on wheels or stabilisers, it is always possible to check the levelling status in order to make the appropriate corrections to ensure maximum stability.

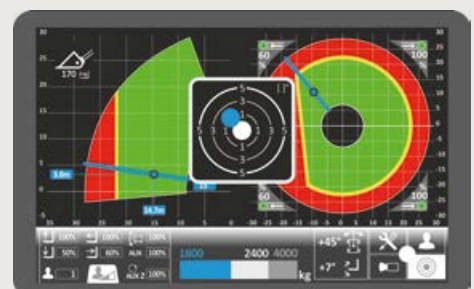

Performance

Power at your Fingertips

Merlo Rotating telehandlers are equipped with a hydrostatic transmission, powered by a combustion engine, which enables them to reach a maximum speed of 40 km/h, depending on the model.

Featuring permanent four-wheel drive, the Merlo telehandlers have excellent braking capacity when the accelerator pedal is released, guaranteeing high torque to the wheels during material handling and transfers, as well as millimetric precision of movements when positioning the load. The exclusively designed axles are manufactured and developed in-house by Merlo, and can be equipped with differential lock to ensure traction on any terrain, regardless of how unstable. The balance of the vehicle's weight, the design of the boom and hydraulic components allow for high telescopic capabilities without impacting the dimensions, or the fuel consumption of the machine.

Engines

All models have the engine in a longitudinal direction, on the right side of the frame. This ensures maximum accessibility to the components during scheduled and/or extraordinary maintenance operations.

The power range of the installed engines is between 75 and 170 HP. Finally, the electronic management of the injection system allows Merlo to precisely and smoothly adjust the power delivery according to the customer's requirements.



Axles and Brakes

Axles are available in two versions: with **epicyclic reducers** to maximise the torque transmitted to the wheels, or with **portal reducers** to increase ground clearance. Both axle variants are designed and manufactured in-house to offer the best solution in terms of strength, service life and efficiency. Depending on the model, the axles are equipped with dry disc brakes or wet brakes, always sized to ensure maximum braking performance. All bearings and bushings are designed to ensure a longer service life and reduce the need for maintenance.

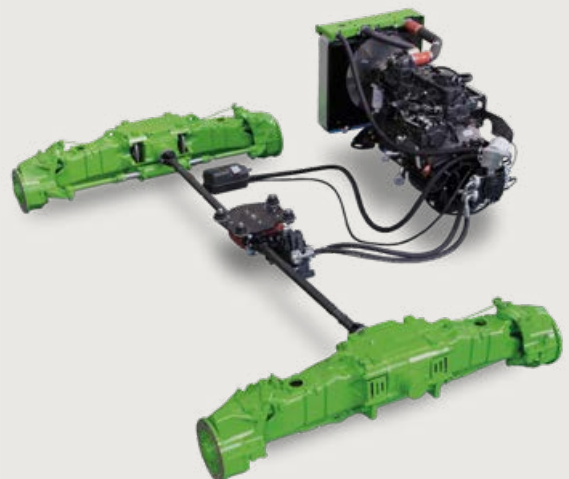

Hydraulic system

These are the only models on the market equipped with two separate circuits for hydraulics and hydrostatics with two different oil reservoirs. The hydraulic circuit consists of a load-sensing variable displacement pump combined with a Flow-Sharing distributor to guarantee lower fuel consumption and enhanced ease of use, performing up to three simultaneous movements without difficulty. The Plus version features a dual LS hydraulic pump to ensure maximum hydraulic performance.

CVTRONIC

Merlo's continuously variable CVTronic smart transmission combines the advantages of a hydrostatic transmission with the same performance and yield as a traditional CVT system. Compared to a conventional hydrostatic transmission, the CVTronic provides:

- A 12% increase in torque
- Reduced consumption thanks to its excellent efficiency
- Ease of use, thanks to the elimination of gear changes.

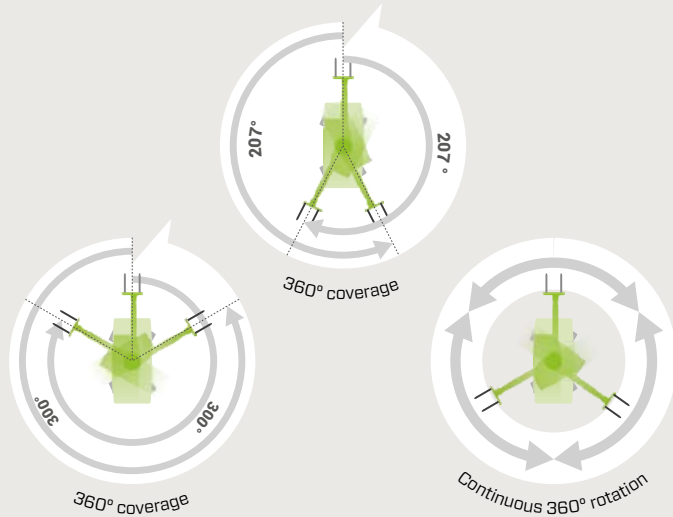

Stabilisers

All rotating telehandlers are equipped with a self-stabilising and self-levelling system. In order to achieve the correct stabilisation, depending on the product ranges, there are two different solutions.

- On/off stabilisers, they are characterised by a lever movement and provide a single stabilisation position. They ensure maximum ease of use and speed.
- Multi-position stabilisers characterised by an arm that can slide out externally and a vertically descending stabilising foot. This solution allows the machine to be stabilised in an infinite number of configurations ranging from the fully retracted boom to its maximum extension, meeting the needs of the job site.



Turret rotation

Merlo rotating telehandlers can be equipped with different solutions for turret rotation. Depending on the machine configuration, three types of maximum turret rotation are available:

- 400° rotation, foresees a mechanical rotation limiter positioned at 207° on the right and left sides, achieving a maximum rotation greater than 400°.
- 600° rotation, with an electronic limiter placed at 300° on the right and left sides.
- Continuous rotation, there is no limiter and the turret can continue to rotate seamlessly



Aerial work platform

As a standard, the rotating telehandlers are all prearranged for use with aerial work platforms. This solution, complying with EN280 standard, assures an increased level of active and passive safety during work at heights, and enhances machine versatility. In addition, the new management system applied to the aerial work platforms allows the speed of movement to be adjusted proportionally according to load and boom position. This speeds up work operations to the benefit of users.

Comfort

The best work station

The exclusive cab, fitted with vibration-damping silent-blocks on the frame, has been developed to guarantee our customers a record level of comfort, with a width of 1010mm and a large glass surface of 4,3sq.m ensuring the best roominess in its class. Simple and easy access to the cab is guaranteed by the 180° opening door, the high distance between the upright and steering wheel, and the correct positioning of the steps and handles for access. Acoustic and thermal comfort have also been taken care of down to the smallest detail in all telehandler ranges, thanks to intensive research into the most innovative technical solutions and materials, ensuring optimal soundproofing and thermal insulation. Finally, the entry of dust into the passenger compartment is prevented thanks to the cab pressurisation compliant with ISO 10263-3 standards*

NOTES: *pressurisation level not approved for use of pesticides, work in hazardous environments, with asbestos, etc.

Cab entry

Easy access to the cab is ensured by the 180° opening door, which maximises entry space, and the large distance between the upright and steering wheel. The side window, which is independent of the door body, can be locked in the open position to maximise air exchange, visibility and direct contact with those working outside near the machine. It is possible to unlock the window either by means of the control on the floor or with the release knob installed directly on the window to facilitate unlocking operations.



Cab

Merlo's design guarantees high levels of **functionality and comfort**; grouping the information provided to the driver and the controls of the various systems and devices for optimal ergonomics. The reverse shuttle on the steering wheel is also present on the joystick.

- 1 - ASCS display
- 2 - Capacitive joystick
- 3 - Steering wheel and transmission controls
- 4 - Transmission display
- 5 - Pedals
- 6 - Accessory compartment and air conditioning controls

The steering column, including the steering wheel and transmission display, can be adjusted in height. The display shows all information dedicated to road circulation (levels, temperatures, speed, etc.).

Air-conditioning

Developed according to automotive standards, the air conditioning system of Merlo handlers **cuts the warm-up and cool-down times in half** compared to conventional models. The intake opening is located on the side of the cab, away from any potential sources of dust and dirt. Furthermore, inside there are 8 vents, three of which are dedicated to defrosting the windscreen, for optimal climate comfort.

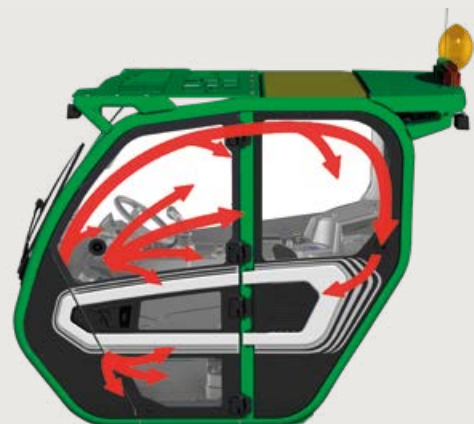

Boom Suspensions

The active boom suspension system (BSS - Boom Suspension System) is available as an option, which protects the load during transfer and maintains a high level of driving comfort on rough terrain. The **suspension is automatically deactivated** at low speed (below 3 km/h), for boom maximum precision and power.



Merlo Carriage

Merlo machines have a carriage designed to ensure record-breaking performance with every implement, without compromising on lightness, which is essential for ensuring an exceptional lifting capacity. The maximum rotation facilitates the loading and unloading of material with buckets. The **Tac-lock device**, which comes **standard** on all the models, guarantees maximum operating comfort, allowing the implements to be hydraulically locked from the cab.

Tilting Cab

Merlo's exclusive cab tilting system ensures high levels of comfort, operational visibility, ergonomics and safety. From the drivers' seat, the operator is able to use a button to activate the cab's tilting feature. The tilt angle raises up to 20° and allows the operator to monitor any movements or positional changes of the load when working at height, without having to move their neck into an uncomfortable position for extended periods of time.



Axle Suspension

Merlo's exclusive, electronically-controlled active suspension absorbs vibrations, guaranteeing a more comfortable ride, especially when operating on rough terrain. In addition to reducing transport times and improving operator comfort, Merlo cab suspension also operates as a transversal and frontal inclination corrector, allowing you to work in total safety even on sloped terrain.

Efficiency

Simpler and Smarter

Merlo telehandlers boast the smallest dimensions and lightest weights on the market, guaranteeing reduced manoeuvring space, fuel consumption for transfers and reduced impact on the ground. Excellent manoeuvrability further reduces manoeuvring times, for greater productivity and lower power consumption. In addition, a further reduction in operating costs is provided by the full electronic management of the transmission and engine, which minimises RPM and, consequently, fuel demand. All models in the range are equipped with a double-acting hydraulic service line at the top of the boom and an electrical socket for machine-implement communication, making them compatible with a wide range of specially designed attachments in order to increase the versatility of the machine and allow its use in a wider range of application, thereby reducing depreciation times.

Visibility

Merlo's improved visibility increases range of movement and safety for operators. To achieve these standards of visibility, Merlo has invested in understanding the best position of the cab and boom for the operator. Merlo has also developed a detailed bonnet design and a large glass surface with the aim of ensuring fast, safe and precise operations. In addition, three different brushes are installed on the machine to ensure perfect window cleaning even in heavy rain. Electric controls in the cab control continuous or variable speed operation depending on the weather conditions.



REDUCED CONSUMPTION

Merlo EPD technology

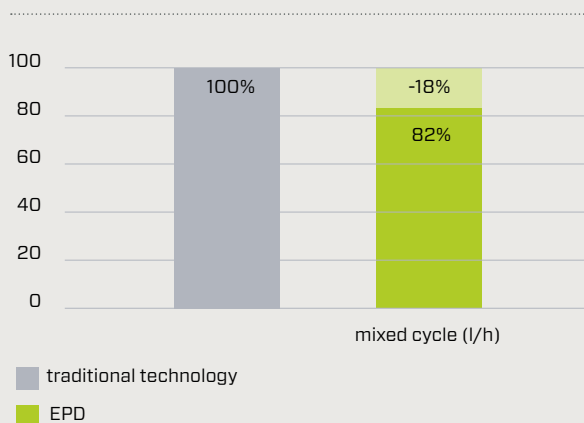

EPD and Self-Accelerating Joystick

The exclusive and innovative EPD (**Eco Power Drive**), applied to hydrostatic transmissions, is a **Merlo patented** system for the electronic control and regulation of the engine and transmission. The EPD automatically controls and adjusts engine speed, hydrostatic pump flow rate and hydrostatic engine displacement according to operating conditions to maximise efficiency and reduce RPM and ensures a reduction in fuel consumption of up to 18%. The annual savings is Euro 3.300 (the figure assumes an average use of 1000 h/year).

The EPD includes the "**self-accelerating joystick**" function, which manages engine speed proportionally to the use of the joystick (the greater the inclination of the joystick, the greater the engine rpm). This feature further optimises fuel consumption and maximises the responsiveness for material handling.

Steering Modes

One of Merlo's development focuses is to **minimise manoeuvring space** while maximising the agility of machines. Merlo axles ensure maximum steering angle for manoeuvring in tight spaces. Additionally, the operator can manage the steering of the machine with three different options according to the specific needs of the job (front wheel steering, pivot steering and crab steering (for lateral movements)).

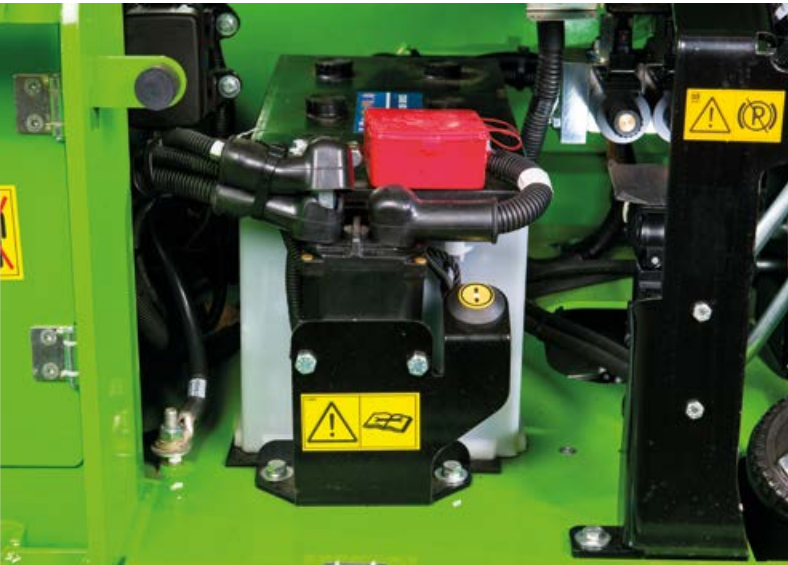
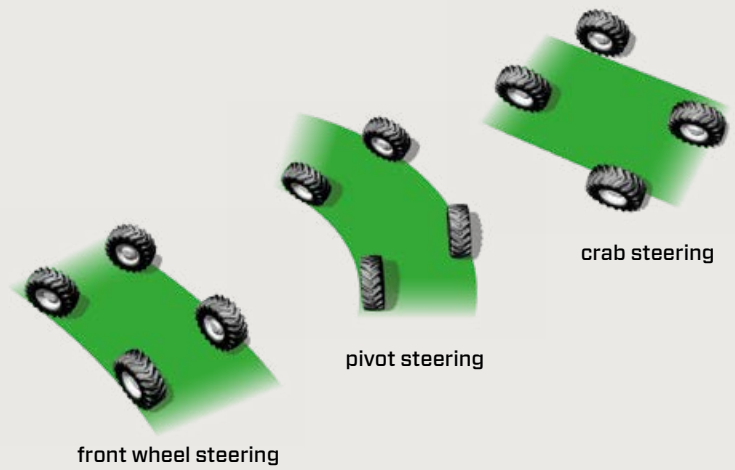

Battery Isolator Switch

As a standard feature, Merlo telehandlers come equipped with an **electric, automatic and timed battery switch** to improve the efficiency and life of the batteries. Removing the key from the ignition switch starts a process which completely disconnects the machine's electrical circuit without compromising the reliability of the machine's electrical control units. With the circuit off, the operator can simply insert the keys into the control panel again to reactivate all functions of the batteries. A button is also available near the battery that allows for forceable disconnection of the battery in order to meet the operational needs of the other utilities.

Capacitive Joystick

All telehandlers in this range are equipped with the innovative capacitive electronic joystick control. This instrument is able to detect the presence of the operator's hand by means of a capacitive type sensor, thus avoiding the need for a special physical control ("dead man" button) to enable the hydraulic movements of the machine. With the joystick it is possible to control all the main hydraulic movements of the machine and implements, with up to 4 independent hydraulic movements on the implement as standard.



Electric Power Supply

All rotary telehandlers in the Merlo range can be equipped with a Plug-in solution, which allows them to operate in total safety without the use of a combustion engine. This equipment allows the telehandler to be connected to a 400 volt power line and operate fully electrically. Merlo's Plug-In solution provides considerable advantages, reducing polluting emissions and noise, facilitating work even in city centres and during evening shifts, and lowering fuel consumption and maintenance costs.

Rotating telehandler range

A new movement concept

The Rotating telehandler models are developed to meet the specific needs of customers operating in the industrial, construction, and infrastructure sectors. The high versatility of the range makes it possible to offer models with reduced dimensions compared to the market's reference standards, improving the ability to work in confined sites while ensuring the record-breaking performance and precision of movement required by big construction sites. The range is equipped with four stabilisers to ensure greater stability and safety when handling loads at heights. Two different categories of machines are available, which in turn can be differentiated into three configurations designed for our customers.

- Entry configuration
- S-Classic configuration
- S-Plus configuration





ROTO 16-18

The models of this family are easy to use and feature a simple interface. Developed to meet the needs of every construction site, rental companies and large construction companies, they offer lifting capacities of 4000 kg, on/off stabilisers and lifting heights of up to 18 metres. Available in two configurations.

Entry Models

- Precise and powerful hydraulics with Load Sensing and Flow sharing technology
- EPD transmission with maximum speed of 25 km/h
- 55 kW/75 hp engine





S-Classic Models

- Precise and powerful hydraulics with Load Sensing and Flow sharing technology
- EPD transmission with maximum speed of 40 km/h
- Active axle suspension
- 90 kW/122 hp engine



ROTO 21-35

The models in this family offer maximum performance and are equipped with Merlo's most innovative technologies. Developed to set a new state of the art, they are used in all applications from construction to logistics and infrastructure. They offer lifting capacities of 5000 kg or 7000 kg, multi-position stabilisers and lifting heights of up to 35 metres.

Available in three configurations.

Entry Models

- Precise and powerful hydraulics with Load Sensing and Flow sharing technology
- EPD transmission with maximum speed of 25 km/h
- 55 kW/75 hp engine





S-Classic Models

- Precise and powerful hydraulics with Load Sensing and Flow sharing technology
- EPD transmission with maximum speed of 40 km/h
- Active axle suspension
- 125 kW/170 hp engine

S-Plus Models

- Precise and powerful hydraulics with Load Sensing and Flow sharing double pump
- EPD transmission with maximum speed of 40 km/h
- Active axle suspension
- Cab can be tilted upwards by 20°
- 125 kW/170 hp engine



Technical characteristics

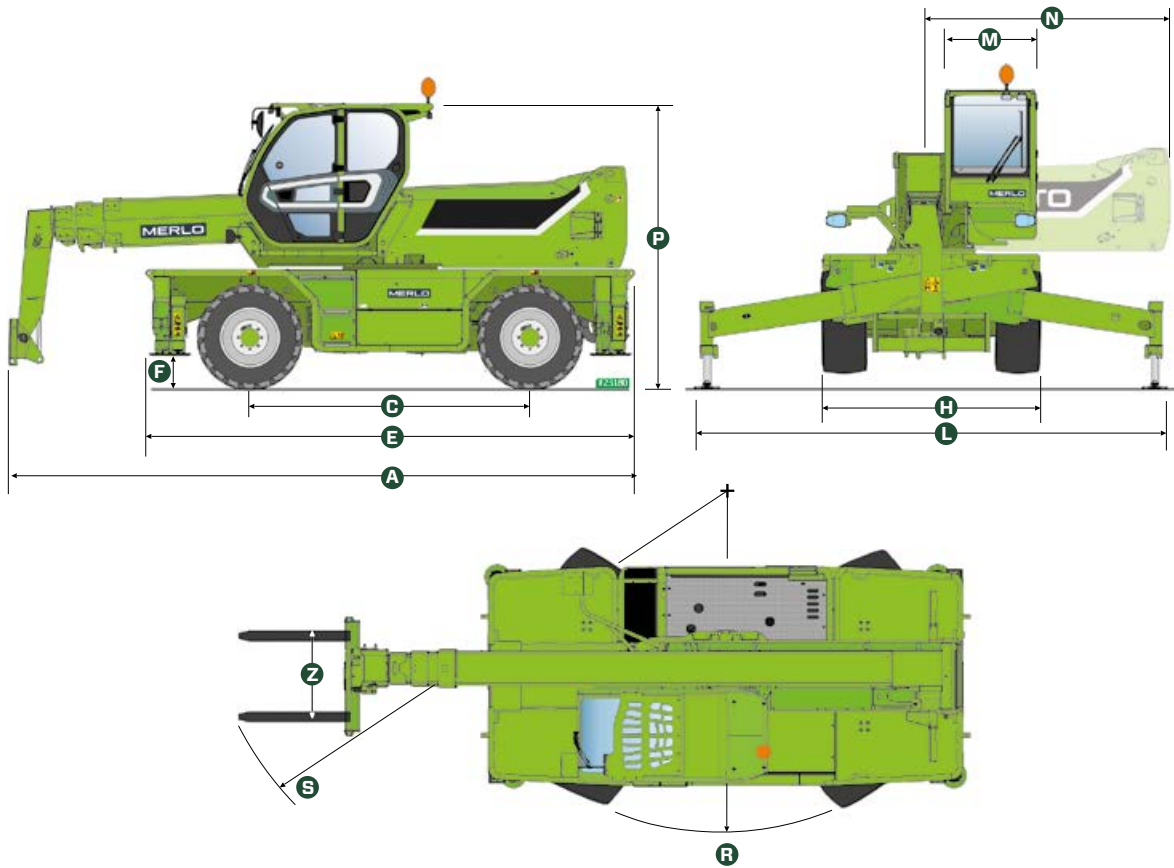

MODEL	DIMENSIONS	A	C	E	F	H	M	N	P	R	S	Z
ROTO40.16	mm	6280	2860	4750	290	2240	1010	2300	2980	4000	5930	850
ROTO40.16S	mm	6280	2860	4750	290	2240	1010	2300	2980	4000	5930	850
ROTO40.18	mm	6030	2860	4750	290	2240	1010	2300	2980	4000	5750	850
ROTO40.18S	mm	6030	2860	4750	290	2240	1010	2300	2980	4000	5750	850
ROTO50.21	mm	6830	3070	5370	370	2430	1010	2600	3120	3850	6100	850
ROTO50.21S	mm	6830	3070	5370	370	2430	1010	2600	3120	3850	6100	850
ROTO50.21SPPLUS	mm	6830	3070	5370	370	2430	1010	2600	3120	3850	6100	850
ROTO50.26	mm	7150	3070	5370	370	2430	1010	2600	3120	3850	6310	850
ROTO50.26S	mm	7150	3070	5370	370	2430	1010	2600	3120	3850	6310	850
ROTO50.26SPPLUS	mm	7150	3070	5370	370	2430	1010	2600	3120	3850	6310	850
ROTO50.30S	mm	7790	3200	5620	290	2490	1010	3170	3160	4500	6770	850
ROTO50.30SPPLUS	mm	7790	3200	5620	290	2490	1010	3170	3160	4500	6770	850
ROTO70.24S	mm	7545	3200	5620	290	2490	1010	3170	3160	4500	6770	850
ROTO70.24SPPLUS	mm	7545	3200	5620	290	2490	1010	3170	3160	4500	6770	850
ROTO50.35SPPLUS CVTRONIC	mm	8590	3780	6910	315	2540	1010	3690	3325	4840	7130	850
ROTO70.28SPPLUS CVTRONIC	mm	8310	3780	6910	315	2540	1010	3690	3325	4840	6920	850

MODEL	ROTO40.16	ROTO40.16S	ROTO40.18	ROTO40.18S	ROTO50.21	ROTO50.21S	ROTO50.21S PLUS
Unladen weight (kg)	12900	13000	13500	13600	15800	15800	16500
Maximum load capacity (kg)	4000	4000	4000	4000	4950	4950	4950
Lift height (m)	15,8	15,8	17,7	17,7	21	21	21
Maximum reach (m)	13,2	13,2	15	15	17,9	17,9	17,9
Reach at max. load capacity (m)	5,5	5,5	5,5	5,5	7	7	7
Load capacity at max. reach (kg)	700	700	400	400	800	800	800
Load capacity at max. lift height (kg)	2500	2500	3000	3000	2500	2500	2500
Frame levelling (%)	-	+/-12, +/-4	-	+/-12, +/-4	-	+/-12, +/-4	+/-12, +/-4
Engine	FPT F34	FPT F36	FPT F34	FPT F36	DEUTZ TCD	FPT NEF45	FPT NEF45
Displacement / cylinders	3400/4	3600/4	3400/4	3600/4	3600/4	4500/4	4500/4
Engine power (kW/HP)	55,4/75	90/122	55,4/75	90/122	55,4/75	125/170	125/170
Anti-pollution technology	Stage V DOC + DPF	Stage V DOC + DPF+ SCR	Stage V DOC + DPF	Stage V DOC + DPF+ SCR	Stage V DOC+DPF	Stage V DOC + DPF+ SCR	Stage V DOC + DPF+ SCR
Maximum speed (km/h)	25	40	25	40	25	40	40
Fuel tank capacity (l)	140	140	140	140	150	150	150
AdBlue tank capacity (l)	-	18	-	18	-	43	43
Hydrostatic transmission	YES - 2V	YES - 2V	YES - 2V	YES - 2V	YES - 2V	YES - 2V	YES - 2V
EPD	STD	STD	STD	STD	STD	STD	STD
Self-accelerating joystick	STD	STD	STD	STD	STD	STD	STD
Hydraulic pump	LS + FS	LS + FS	LS + FS	LS + FS	LS + FS	LS + FS	2 - LS + FS
Delivery/pressure (l/min-bar)	103,5 - 250	103,5 - 250	103,5 - 250	103,5 - 250	103,5 - 250	138 - 250	138+100 - 250/230
Hydraulic oil tank capacity (l)	162	162	162	162	120	120	120
Cab finishing	PREMIUM	PREMIUM	PREMIUM	PREMIUM	PREMIUM	PREMIUM	PREMIUM
ASCS	Full	Full	Full	Full	Full	Full	Full
ROPS, FOPS LEV II cab	YES	YES	YES	YES	YES	YES	YES
Cab controls	Electronic joystick control	Electronic joystick control	Electronic joystick control	Electronic joystick control	Electronic joystick control	Electronic joystick control	Electronic joystick control
Reverse shuttle	Dual reverse	Dual reverse	Dual reverse	Dual reverse	Dual reverse	Dual reverse	Dual reverse
Boom suspension	NO	NO	NO	NO	NO	NO	NO
Hydropneumatic suspension	NO	YES	NO	YES	NO	YES	YES
Tilting Cab	NO	NO	NO	NO	NO	NO	YES
Stabilisers	On/Off	On/Off	On/Off	On/Off	Multi-position	Multi-position	Multi-position
Turret rotation	415°	415°	415°	415°	600°	Continuous	Continuous
Tac-lock	YES	YES	YES	YES	YES	YES	YES
Permanent four-wheel drive	YES	YES	YES	YES	YES	YES	YES
All-wheel steering	YES	YES	YES	YES	YES	YES	YES
Standard tyres	400/70-20	400/70-20	400/70-20	400/70-20	18-22,5	18-22,5	18-22,5

ROTO40.16

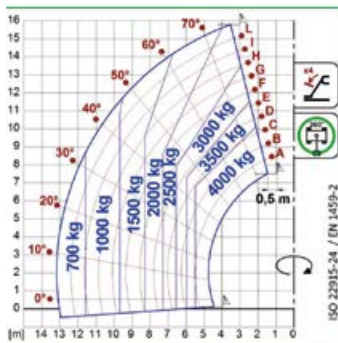

ROTO40.18

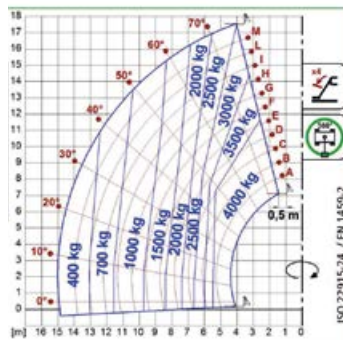

ROTO50.21

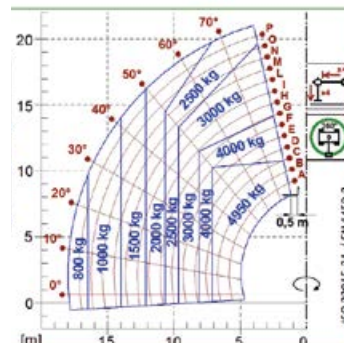

ROTO50.26

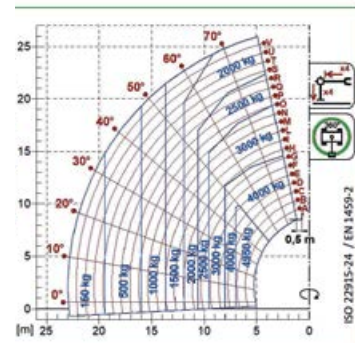

ROTO50.26	ROTO50.26S	ROTO50.26S PLUS	ROTO50.30S	ROTO50.30S PLUS	ROTO70.24S	ROTO70.24S PLUS	ROTO50.35S PLUS CVTRONIC	ROTO70.28S PLUS CVTRONIC
16600	16600	17300	19800	20500	19500	20200	23350	22750
4950	4950	4950	4950	4950	7000	7000	4950	7000
25,9	25,9	25,9	29,2	29,2	24,2	24,2	34	28
22,9	22,9	22,9	25,4	25,4	20,5	20,5	27	23,2
7	7	7	9,1	9,1	5,9	5,9	10,1	6,5
150	150	150	400	400	900	900	500	850
1500	1500	1500	2000	2000	3000	3000	2000	3000
-	+/-12, +/-4	+/-12, +/-4	+/-12, +/-4	+/-12, +/-4	+/-12, +/-4	+/-12, +/-4	+/-12, +/-4	+/-12, +/-4
DEUTZ TCD	FPT NEF45	FPT NEF45	FPT NEF45	FPT NEF45	FPT NEF45	FPT NEF45	FPT NEF45	FPT NEF45
3600/4	4500/4	4500/4	4500/4	4500/4	4500/4	4500/4	4500/4	4500/4
55,4/75	125/170	125/170	125/170	125/170	125/170	125/170	125/170	125/170
Stage V DOC+DPF	Stage V DOC + DPF+ SCR	Stage V DOC + DPF+ SCR	Stage V DOC + DPF+ SCR	Stage V DOC + DPF+ SCR	Stage V DOC + DPF+ SCR	Stage V DOC + DPF+ SCR	Stage V DOC + DPF+ SCR	Stage V DOC + DPF+ SCR
25	40	40	40	40	40	40	40	40
150	150	150	150	150	150	150	150	150
-	43	43	43	43	43	43	43	43
YES - 2V	YES - 2V	YES - 2V	Yes - 2V	YES - 2V	Yes - 2V	YES - 2V	CVTronic	CVTronic
STD	STD	STD	STD	STD	STD	STD	STD	STD
STD	STD	STD	STD	STD	STD	STD	STD	STD
LS + FS	LS + FS	2 - LS + FS	LS + FS	2 - LS + FS	LS + FS	2 - LS + FS	2 - LS + FS	2 - LS + FS
103,5 - 250	138 - 250	138+100 - 250/230	138 - 250	138+100 - 250/230	138 - 250	138+100 - 250/230	158+100 - 260	158+100 - 260
120	120	120	120	120	120	120	220	220
PREMIUM	PREMIUM	PREMIUM	PREMIUM	PREMIUM	PREMIUM	PREMIUM	PREMIUM	PREMIUM
Full	Full	Full	Full	Full	Full	Full	Full	Full
YES	YES	YES	YES	YES	YES	YES	YES	YES
Electronic joystick control	Electronic joystick control	Electronic joystick control	Electronic joystick control	Electronic joystick control	Electronic joystick control	Electronic joystick control	Electronic joystick control	Electronic joystick control
Dual reverse	Dual reverse	Dual reverse	Dual reverse	Dual reverse	Dual reverse	Dual reverse	Dual reverse	Dual reverse
NO	NO	NO	OPT	OPT	OPT	OPT	OPT	OPT
NO	YES	YES	YES	YES	YES	YES	YES	YES
NO	NO	YES	No	YES	No	YES	YES	YES
Multi-position	Multi-position	Multi-position	Multi-position	Multi-position	Multi-position	Multi-position	Multi-position	Multi-position
600°	Continuous	Continuous	Continuous	Continuous	Continuous	Continuous	Continuous	Continuous
YES	YES	YES	YES	YES	YES	YES	YES	YES
YES	YES	YES	YES	YES	YES	YES	YES	YES
YES	YES	YES	YES	YES	YES	YES	YES	YES
18-22,5	18-22,5	18-22,5	445/65 R22,5	445/65 R22,5	445/65 R22,5	445/65 R22,5	445/80 R 25	445/80 R 25

ROTO50.30

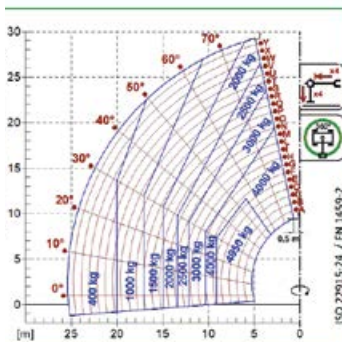

ROTO50.35

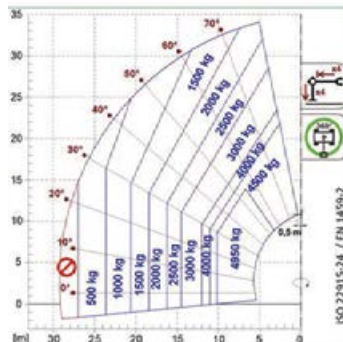

ROTO70.24

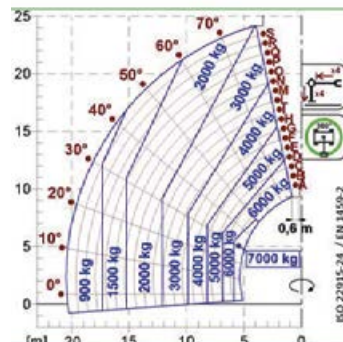

ROTO70.28

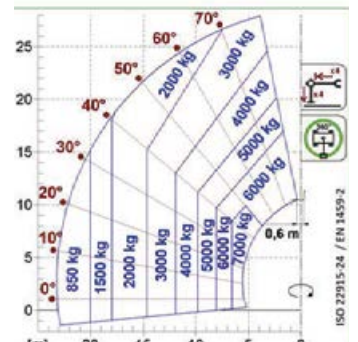



Your Merlo dealer

MERLO S.p.A.

Via Nazionale, 9 - 12010 S. Defendente di Cervasca (CN) - Italy
Tel. +39 0171 614111 - Fax +39 0171 684101
www.merlo.com - info@merlo.com

