



**Built To Be
The Best**

Thwaites

Welcome to Thwaites

Over 80 Years of engineering excellence.

Built To Last, Built To Be The Best.

The Thwaites name is synonymous with the best-quality dumpers on the market. Advanced design and investment in tooling provide today's customers with the very best products at the cutting edge of technology. This means more than just the strength and reliability you expect from Thwaites - it means an increased focus on customer satisfaction, safety and ergonomics across the range.

Thwaites offer a range of quality, reliable site dumpers, from 1 tonne to 9 tonne capacity - all built to exacting standards with hirers and contractors in mind. When you choose Thwaites you are safe, compliant, competitive, and part of a heritage of owners and operators who love their Thwaites dumper.



80+ Years Of Success

All machines are exclusively designed and manufactured at our Leamington Spa, Warwickshire factory. Thwaites are proud that for over 80 years, we have continued to engineer solutions for the plant hire and construction markets in over 70 countries across five continents.

Thwaites blend the very latest laser cutters and robot welders, with the cleanest, most efficient paint spraying processes. A highly skilled team of time-served craftsmen, ensure Thwaites dumpers are consistently at the forefront of safety, design and development.

At every stage of the manufacturing process, each component has to pass the most stringent tests. Once assembled, all dumpers go through a comprehensive pre-despatch inspection prior to being delivered to either the Thwaites distributor or the final customer.

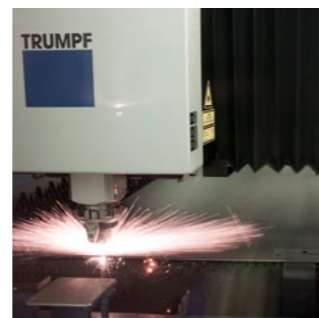
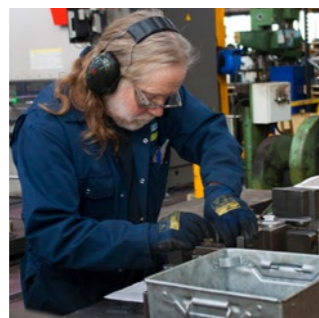
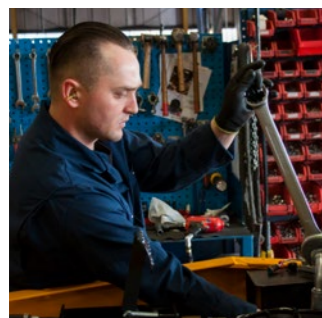

Quality Counts

With the highest safety standards and fewer breakdowns or repairs, owning and operating a Thwaites dumper will reduce your costs and improve margins. Thwaites dumpers are built to last, so when it is time to 'trade-in', you also benefit from market leading residuals.

Thwaites dumpers go to market via a distribution model. In the UK we partner exclusively with 12 leading, family owned, plant sales businesses, carefully selected to ensure our distributor network reflects the values of the Thwaites brand.

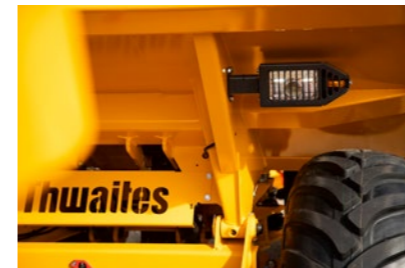

A Family Business

Basil Thwaites founded the company in 1937, initially designing and manufacturing agricultural machinery. In 1947 Thwaites began producing construction equipment including dumpers, and so a relationship with the construction market was established, which remains to this day.

Since the early 1960's the Wills family have been involved in guiding and developing the company. Today the Wills family remains actively involved in the business, ensuring the Thwaites name is as renowned and recognised by today's generation of dumper owners and operators, as it has throughout the company's 84 year history.

Features & Benefits in Detail

Ensuring operator safety, reducing risk on site and improving performance.

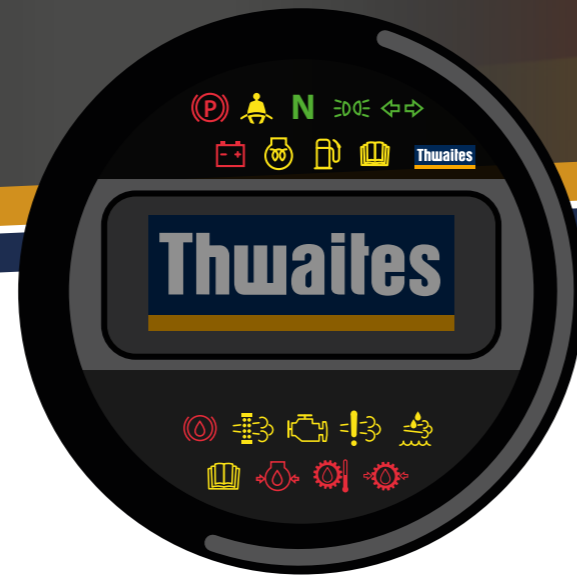

Dashboard

Multifunction display includes:

- Fuel level indicator (plus low fuel warning light)
- Hour meter
- Tachometer (Engine RPM)
- Engine coolant temperature
- Detailed engine service code and reason displayed

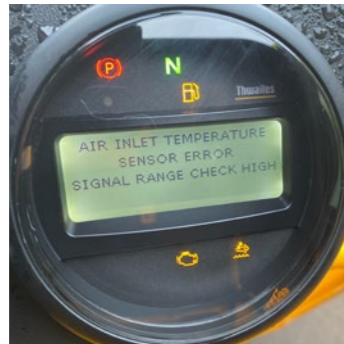

GPS Speedometer

- Optional on machines over 3.5 Tonnes - a useful addition on machines which are to be road registered

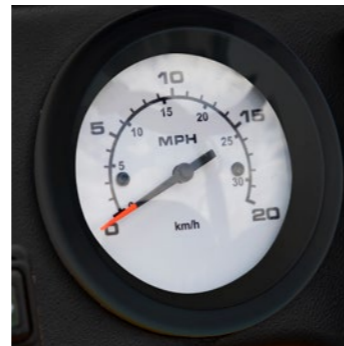

SAHR Handbrake

- Spring Applied Hydraulic Release
- Actuates the main brakes built in to the rear axle
- Handbrake automatically engages in the event of an engine stop
- Proportional braking in emergency use
- No manual adjustment required (as there are no separate cables or calipers to adjust)

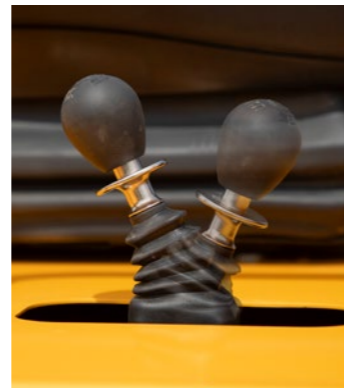

Camera Monitor

- 5" screen with 150° camera viewing angle
- NB: Cabbed machines include a rear-facing camera, activated when reverse is selected



LED Road Lights

- Conforms to ISO 12509:2004
- Incl. Daytime Running Lights



- Operation sequence: DRL, Sidelights, Headlights
- Rear LED lights protected in the mudguard (not 1&1.5T)
- Low electrical load
- Long service life



Hi-Viz Steps

- Flexible bottom step provides improved accessibility whilst reducing the risk of step damage
- Common design used across most machines to simplify repairs
- Conforms to ISO 2867:2011



Twin Beacon Posts

- LED amber & green beacons connected to drive-disconnect system and seat belt latch respectively
- Where the green beacon is fitted, this will now be mounted in the same way as the amber beacon (flexible pole mount)



Find out what equipment is standard or optional on each machine, on page 20.

Meet The Machines

Greater protection

From the spring of 2024, a new directive will mean that site dumpers with an unladen weight of 4.5-tonne and above, must offer greater protection than a roll bar. The EN474 Earthmoving Machinery Safety-Part 1 directive, will mandate that dumpers with an unladen weight in excess of 4.5-tonne, will be manufactured with a secondary means of protection such as a FOPS cab protection to ISO 3471 & 3449.

Safer braking

From the spring of 2024, a new directive will ensure braking system improvements are made, giving consistent control, response and reaction, when the machine foot brake is depressed. This will be achieved by only fitting hydrostatic transmissions to all Thwaites dumpers.

Machines purchased prior to the spring of 2024 will be unaffected by the changes.

1 Tonne Hi Tip

Max Safe Load	1000 kg
Unladen Weight	1295 kg
Heaped Load	500 litres
Max Speed	12 km/h

MACH 2001 **HYDROSTATIC**



Key features & benefits

Market leading and the hirers favourite, the Thwaites 1 Tonne Hi Tip, Stage V dumper is easily transported by trailer. This is the ideal machine when working in confined spaces or with limited access.

Powered by a 15.9 Kw Yanmar engine, delivering 66.4 Nm of torque for optimum traction, and is driven by a Hydrostatic Transmission making it very easy to operate.

This dumper is 1115 mm wide for optimum stability, but can be specified with optional narrow wheels, for an overall width of just 982 mm, making it ideal for narrow access jobs.

The compact Thwaites 1 Tonne Hi-Tip dumper is an effective and efficient skip loader, ideal for use in the building of house extensions and property landscaping, providing contractors and hirers with amazing versatility and improved performance.

Safe, compliant and competitive.

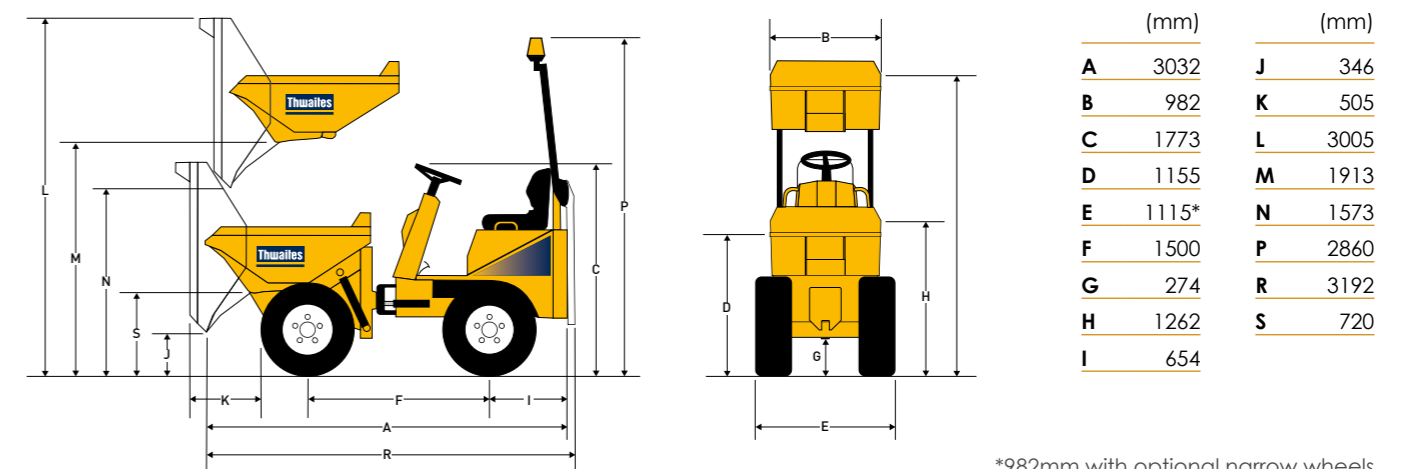

*982mm with optional narrow wheels

1 Tonne Power Swivel

Max Safe Load	1000 kg
Unladen Weight	1300 kg
Heaped Load	585 litres
Max Speed	12 km/h

MACH 2002 HYDROSTATIC



Key features & benefits

Market leading and the hirers favourite, the Thwaites 1 Tonne Power Swivel, Stage V dumper is the ideal machine when working in confined spaces or with limited access and is easily transported by trailer.

Powered by a 15.9 kW Yanmar engine, delivering 66.4 Nm of torque for optimum traction, this dumper is driven by a Hydrostatic Transmission making it very easy to operate.

The Power Swivel skip enables a 90° rotation left and right, allowing the machine easier access to tip loads in restricted areas, giving the operator greater control and reducing risk on site.

Easy to service and maintain with market leading residuals.

Safe, compliant and competitive.

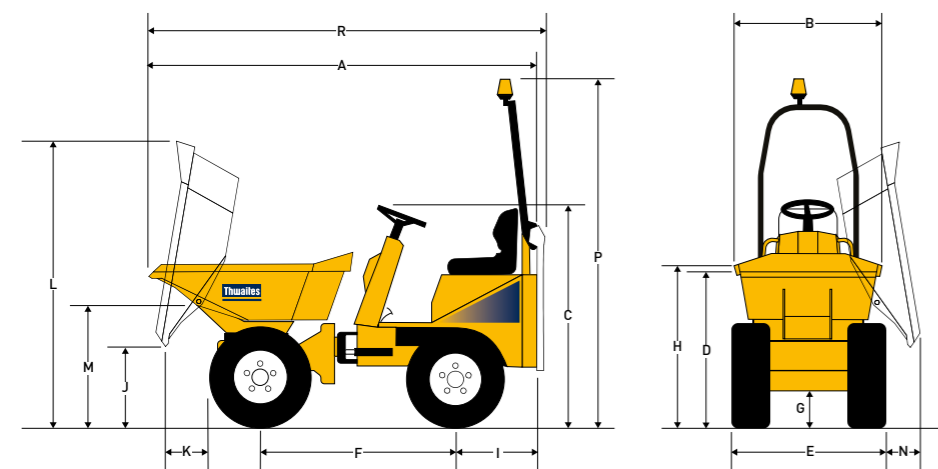

	(mm)		(mm)
A	3062	J	642
B	1151	K	461
C	1773	L	2244
D	1204	M	901
E	1195	N	154
F	1500	P	2860
G	274	R	3222
H	1256		
I	654		

1.5 Tonne Power Swivel

Max Safe Load	1500 kg
Unladen Weight	1355 kg
Heaped Load	800 litres
Max Speed	12 km/h

MACH 2003 HYDROSTATIC



Key features & benefits

Market leading and the hirers favourite, the Thwaites 1.5 Tonne Power Swivel, Stage V dumper is easily transported by trailer, and is the ideal machine for working in confined spaces or on projects with limited access.

Powered by a 15.9 kW Yanmar engine, delivering 66.4 Nm of torque for optimum traction, this dumper is driven by a Hydrostatic Transmission making it very easy to operate.

The Power Swivel skip enables a 90° rotation left and right, allowing the machine easier access to tip loads in restricted areas, giving the operator greater control and reducing risk on site.

Easy to service and maintain with market leading residuals.

Safe, compliant and competitive.

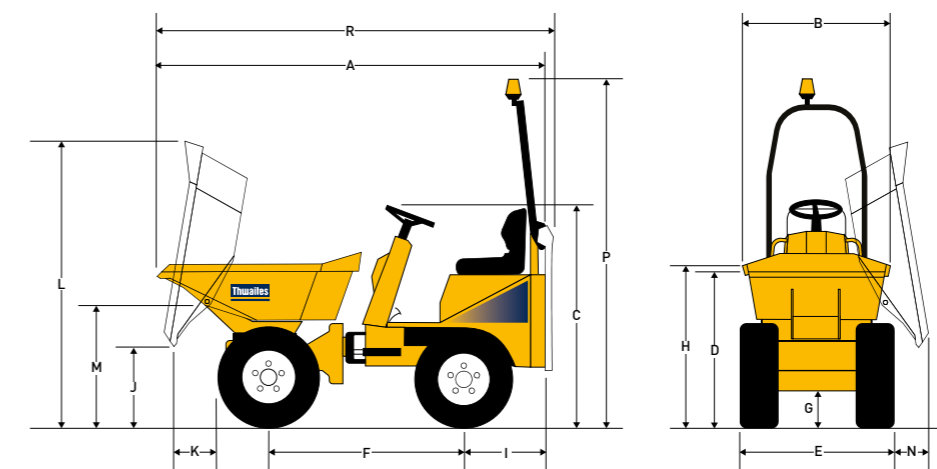

	(mm)		(mm)
A	3097	J	651
B	1300	K	442
C	1773	L	2270
D	1286	M	901
E	1300	N	177
F	1600	P	2860
G	274	R	3257
H	1328		
I	654		

2 Tonne Front Tip

Max Safe Load	2000 kg
Unladen Weight	1990 kg
Heaped Load	1240 litres
Max Speed	15 km/h

MACH 2076 HYDROSTATIC



Key features & benefits

The Thwaites 2 Tonne Front Tip, Stage V dumper is manufactured with contractors and hirers in mind – ensuring operator safety, reducing risk on site and improving performance. Powered by an 18.1 kW 3-cylinder Yanmar engine, delivering 107 Nm max torque for optimum traction and control, this machine is driven by a Hydrostatic transmission, making it simple and straightforward to operate.

Robust and reliable, this machine has a fully welded 5 mm steel plate skip with reinforced box section fitted to minimise skip damage.

Each dumper is supplied as standard with a Spring Applied Hydraulic Release (SAHR) Handbrake, ROPS frame, towing bracket, LED beacons and a reverse alarm. Full LED road lights including daytime running lights can be fitted as an optional extra.

Easy to service and maintain with market leading residuals.

Safe, compliant and competitive.

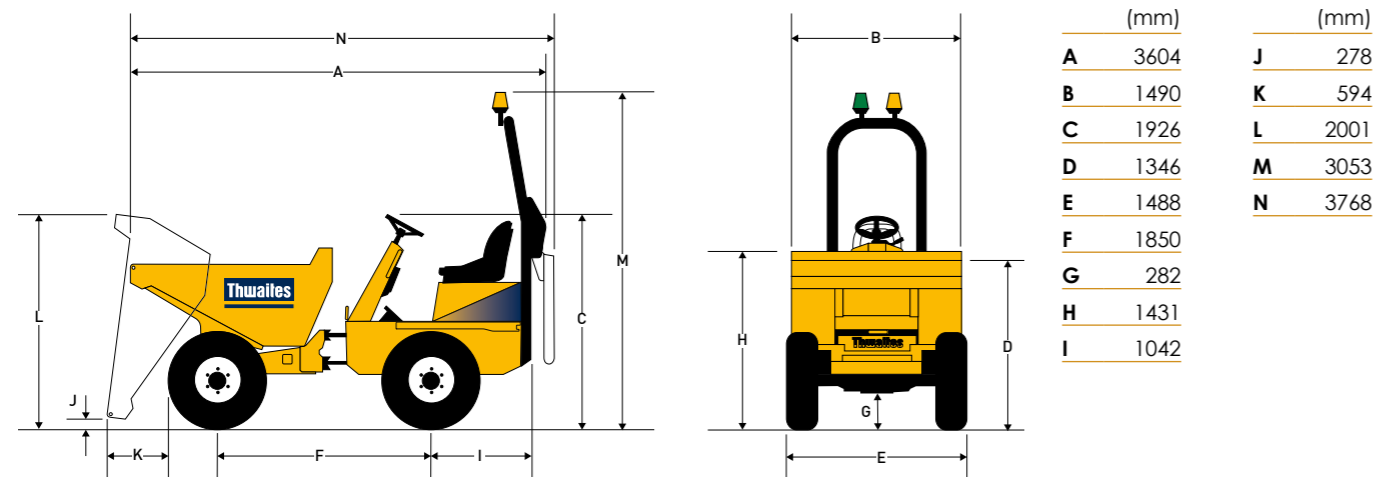

2 Tonne Hi Swivel

Max Safe Load	2000 kg
Unladen Weight	2360 kg
Heaped Load	1205 litres
Max Speed	15 km/h

MACH 2071 HYDROSTATIC



Key features & benefits

The Thwaites 2 Tonne Hi Swivel, Stage V dumper is manufactured with contractors and hirers in mind – ensuring operator safety, reducing risk on site and improving performance. Powered by an 18.1 kW 3-cylinder Yanmar engine, delivering 107 Nm max torque for optimum traction and control, this machine is driven by a Hydrostatic transmission, making it simple and straightforward to operate.

Robust and reliable, this machine has a fully welded 6 mm steel plate skip with reinforced box section fitted to minimise skip damage. The Hi-Swivel dumper enables a 90° rotation left and right, with an additional 490mm of height to the tipping point, providing contractors and hirers with additional versatility and improved performance.

Each dumper is supplied as standard with a Spring Applied Hydraulic Release (SAHR) Handbrake, ROPS frame, towing bracket, LED beacons, reverse alarm and full LED road lights including daytime running lights.

Safe, compliant and competitive.

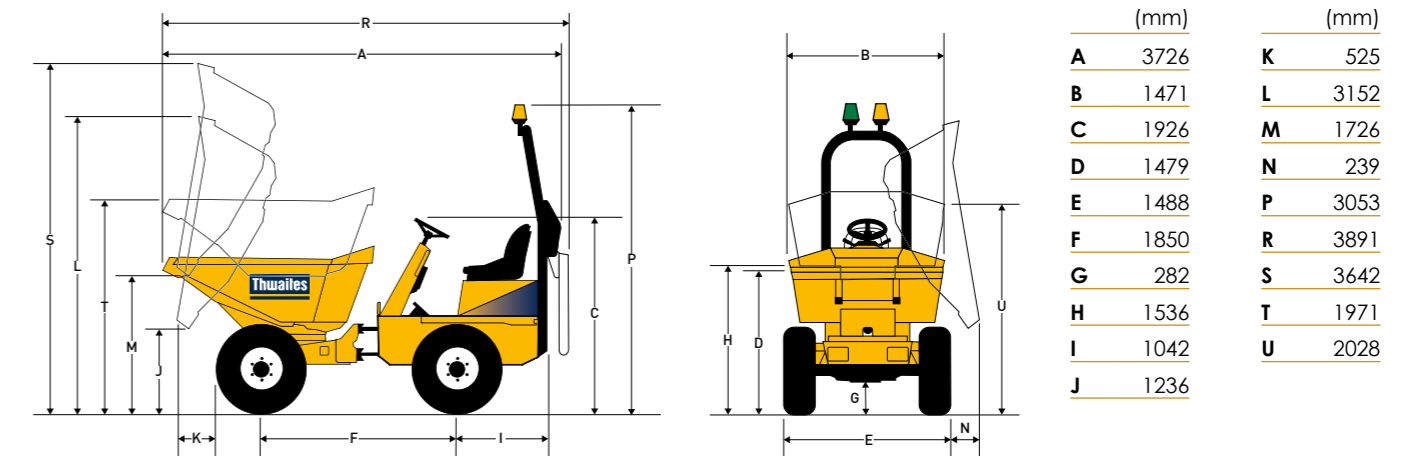

2.3 Tonne Power Swivel

Max Safe Load 2300 kg
 Unladen Weight 2150 kg
 Heaped Load 1205 litres
 Max Speed 15 km/h

MACH 2077 HYDROSTATIC



Key features & benefits

The Thwaites 2.3 Tonne Power Swivel, Stage V dumper is manufactured with contractors and hirers in mind – ensuring operator safety, reducing risk on site and improving performance. Powered by an 18.1 kW 3-cylinder Yanmar engine, delivering 107 Nm max torque for optimum traction and control, this machine is driven by a Hydrostatic transmission, making it simple and straightforward to operate.

This compact-plus machine is available exclusively as a Power Swivel machine, giving optimum performance when space is at a premium. The Power Swivel skip enables a 90° rotation left and right, allowing the machine easier access to tip loads in restricted areas, giving the operator greater control and reducing risk on site.

Each dumper is supplied as standard with a Spring Applied Hydraulic Release (SAHR) Handbrake, full LED road lights including daytime running lights, ROPS frame, towing bracket, LED beacons and a reverse alarm.

Safe, compliant and competitive.

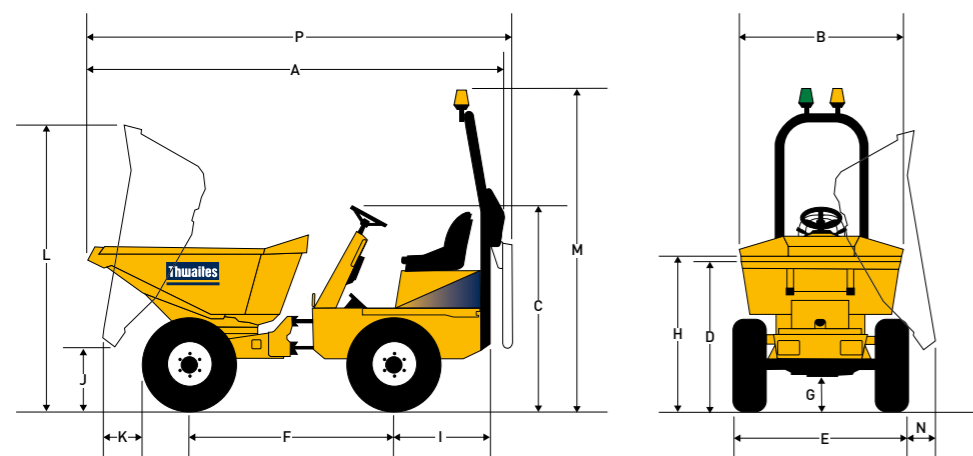

	(mm)		(mm)
A	3726	J	728
B	1471	K	475
C	1926	L	2671
D	1356	M	3053
E	1488	N	189
F	1850	P	3891
G	282		
H	1416		
I	1042		

3 Tonne Front Tip

Max Safe Load 3000 kg
 Unladen Weight 2080 kg
 Heaped Load 1680 litres
 Max Speed 16 km/h

MACH 2081 HYDROSTATIC



Key features & benefits

The Thwaites 3 Tonne Front Tip, Stage V dumper is manufactured with contractors and hirers in mind – ensuring operator safety, reducing risk on site and improving performance. This machine is powered by an 18.1 kW Yanmar engine, delivering 107 Nm max torque for optimum traction and control via a Hydrostatic transmission, making it simple and straightforward to operate.

Robust and reliable, this machine has a fully welded 5 mm steel plate skip with reinforced box section fitted to minimise skip damage.

Each dumper is supplied as standard with a Spring Applied Hydraulic Release (SAHR) Handbrake, ROPS frame, towing bracket and LED beacons. Full LED road lights including daytime running lights can be fitted as an optional extra.

Safe, compliant and competitive.

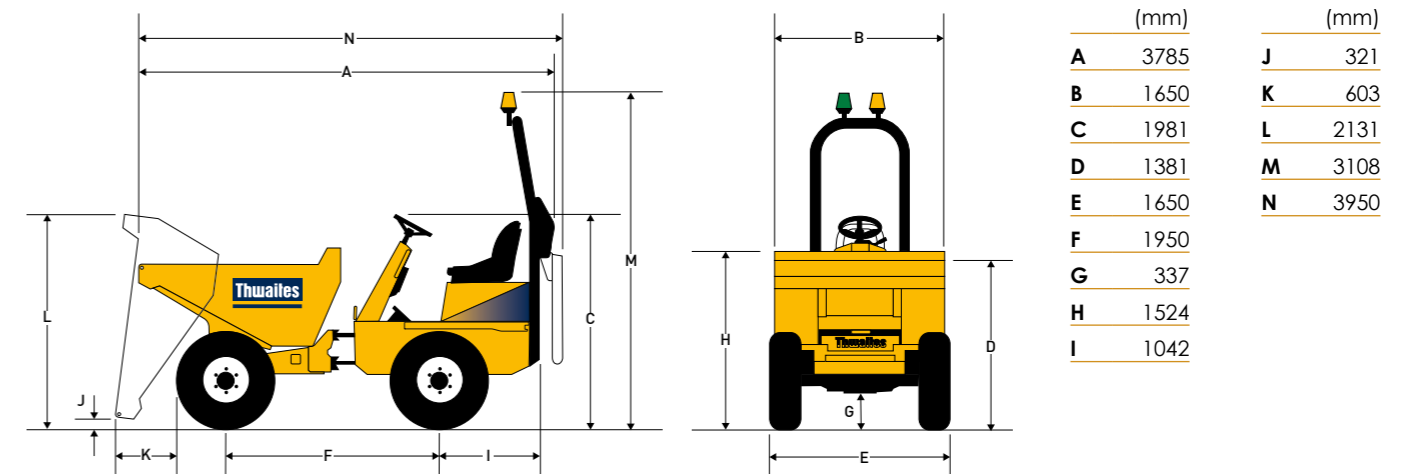

	(mm)		(mm)
A	3785	J	321
B	1650	K	603
C	1981	L	2131
D	1381	M	3108
E	1650	N	3950
F	1950		
G	337		
H	1524		
I	1042		

3 Tonne Power Swivel

Max Safe Load 3000 kg
 Unladen Weight 2250 kg
 Heaped Load 1640 litres
 Max Speed 16 km/h

MACH 2080 HYDROSTATIC



3 Tonne Electric Power Swivel

Max Safe Load 3000 kg
 Unladen Weight 2260 kg
 Heaped Load 1640 litres
 Max Speed 16 km/h

MACH 3080 ELECTRIC-DRIVE



FROM AVAILABLE 2023

Key features & benefits

The Thwaites 3 Tonne Power Swivel, Stage V dumper is manufactured with contractors and hirers in mind – ensuring operator safety, reducing risk on site and improving performance. Powered by an 18.1 kW 3-cylinder Yanmar engine, delivering 107 Nm max torque for optimum traction and control via a Hydrostatic transmission, making it simple and straightforward to operate.

The Power Swivel skip enables a 90° rotation left and right, allowing the machine easier access to tip loads in restricted areas, giving the operator greater control and reducing risk on site. This sturdy and robust machine has a fully welded 6 mm steel plate skip to the mouth and sides with reinforced box section fitted to minimise skip damage.

Each dumper is supplied as standard with a Spring Applied Hydraulic Release (SAHR) Handbrake, ROPS frame, towing bracket, LED beacons and a reverse alarm.

Safe, compliant and competitive.

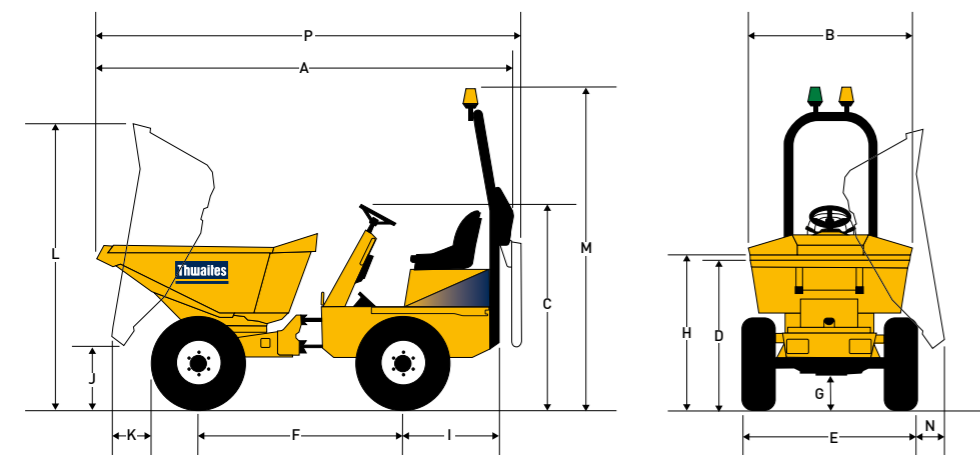

	(mm)		(mm)
A	3934	J	751
B	1638	K	546
C	1981	L	2841
D	1456	M	3180
E	1650	N	388
F	1950	P	4100
G	337		
H	1581		
I	1042		

Key features & benefits

The all-new Thwaites 3 Tonne Electric Power Swivel dumper is manufactured with contractors and hirers in mind. Four 5.75 kWh maintenance free, long-life, lithium-ion batteries, operating at 48V provide the power to drive the machine. Two efficient electric motors (one for drive, one for the hydraulics) give the operator the control expected from a Thwaites dumper.

When compared to the diesel version, the unladen weight is similar, and with the main battery pack and driveline sitting low in the rear chassis, the centre of gravity is lower than the diesel machine too.

Critically, the battery pack will complete a full 8-hour shift of 'normal site operation' from a single charge, which takes between 2 and 8 hours depending on the charger.

The Power Swivel skip enables a 90° rotation left and right, allowing the machine easier access to tip loads in restricted areas. Supplied as standard with a Spring Applied Hydraulic Release (SAHR) Handbrake, ROPS frame, towing bracket and LED beacons.

Safe, compliant and competitive.

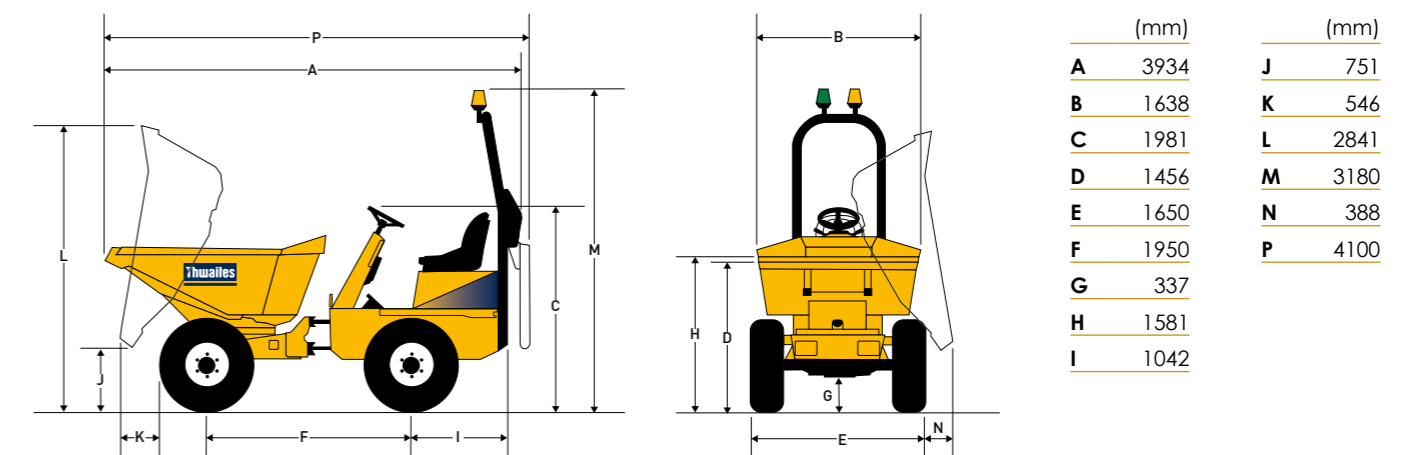

	(mm)		(mm)
A	3934	J	751
B	1638	K	546
C	1981	L	2841
D	1456	M	3180
E	1650	N	388
F	1950	P	4100
G	337		
H	1581		
I	1042		

Please note - machine decals shown are for prototype only.

T450 4.5 Tonne Power Swivel

Max Safe Load	4500 kg
Unladen Weight	3190 kg
Heaped Load	2535 litres
Max Speed	21.4 km/h

MACH 2044 HYDROSTATIC



6 Tonne Front Tip Cabbed

Max Safe Load	6000 kg
Unladen Weight*	4450 kg
Heaped Load	3400 litres
Max Speed*	23.3 km/h

MACH 2360 HYDROSTATIC



FROM AVAILABLE 2024

Key features & benefits

The Thwaites T450 Power Swivel, Stage V dumper is manufactured with contractors and hirers in mind – ensuring operator safety, reducing risk on site and improving performance.

Powered by a 33.3 kW Yanmar engine fitted with a DPF, delivering 142 Nm max torque for optimum traction and control, this machine is driven by a Hydrostatic transmission, making it simple and straightforward to operate.

The Power Swivel skip enables a 90° rotation left and right, allowing the machine easier access to tip loads in restricted areas, giving the operator greater control and reducing risk on site.

Each T450 Power Swivel dumper is supplied as standard with a Spring Applied Hydraulic Release (SAHR) Handbrake, ROPS frame, towing bracket, full LED road lights including daytime running lights, LED beacon, front-facing camera and a reverse alarm.

Optional extras include road mirrors and GPS speedometer.

Safe, compliant and competitive.

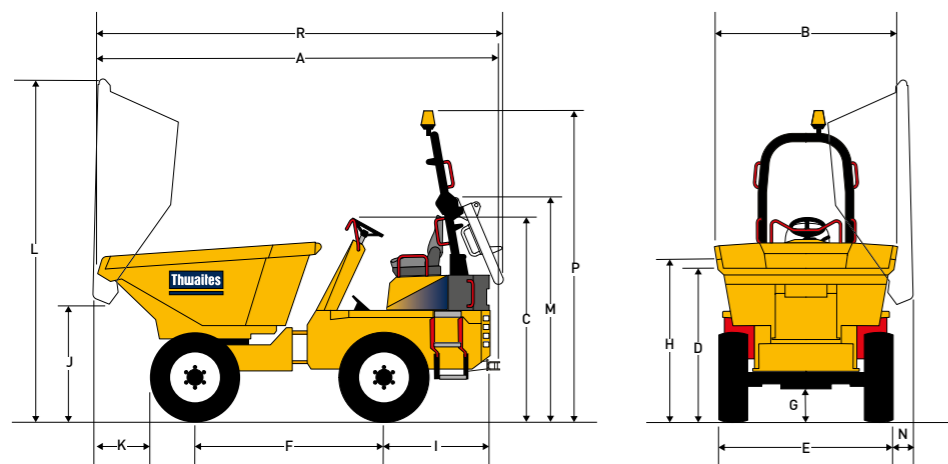

	(mm)		(mm)
A	4211	J	1090
B	1938	K	586
C	2151	L	3425
D	1643	M	2336
E	1851	N	328
F	1978	P	3328
G	319	R	4223
H	1758		
I	1111		

Key features & benefits

The Thwaites 6 Tonne Front Tip Cabbed, Stage V dumper is manufactured with contractors and hirers in mind – ensuring operator safety, reducing risk on site, and improving performance.

The cab is impact tested to level 2 ROPS 3471 and FOPS 3449. As such all Thwaites cabbed dumpers are approved for use by the UK Major Contractors Group.

Powered by a reliable 55kW turbo diesel engine fitted with a DPF to comply with EU Stage V emission regulations, you get all the power, and torque you need, and with no requirement for AdBlue.

A Spring Applied Hydraulic Release (SAHR) Handbrake, 5" screen displaying 150° around machine visibility, hi-vis steps, LED road lights and twin LED beacons are fitted as standard.

Optional extras include a GPS speedo, rear wiper, air suspension seat, heated seat, wheel nut indicators and adjustable work lights.

Safe, compliant and competitive.

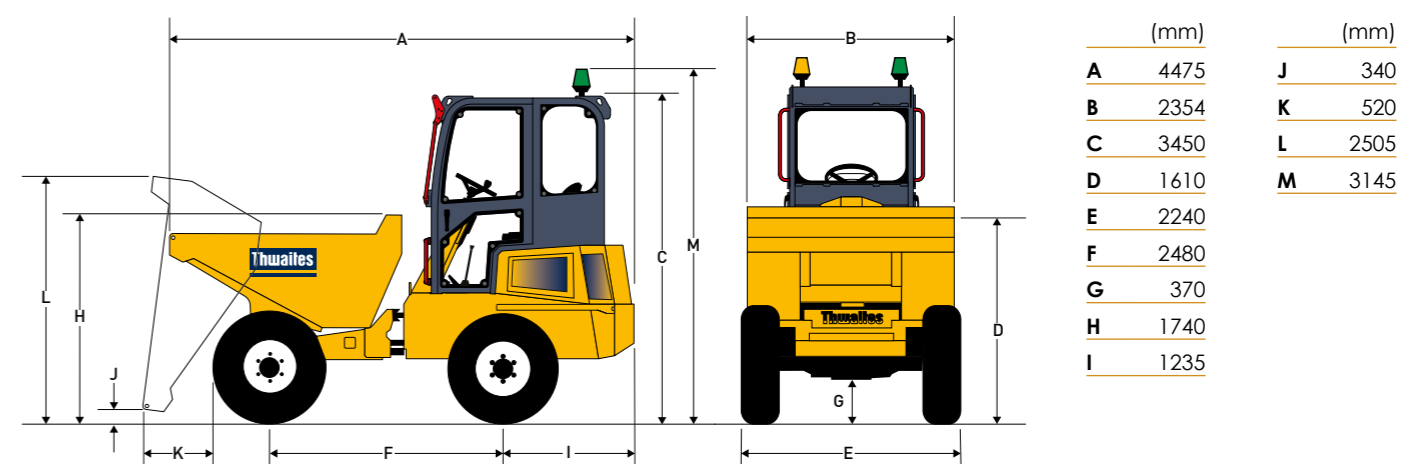

	(mm)		(mm)
A	4475	J	340
B	2354	K	520
C	3450	L	2505
D	1610	M	3145
E	2240		
F	2480		
G	370		
H	1740		
I	1235		

* Weight and speed figures are estimated and may be subject to change upon final build.

6 Tonne Power Swivel Cabbed

Max Safe Load 6000 kg
 Unladen Weight* 4750 kg
 Heaped Load 3150 litres
 Max Speed* 23.3 km/h

MACH 2362 HYDROSTATIC

FROM AVAILABLE 2024



Key features & benefits

The Thwaites 6 Tonne Power Swivel Cabbed, Stage V dumper is manufactured with contractors and hirers in mind – ensuring operator safety, reducing risk on site and improving performance.

The cab is impact tested to level 2 ROPS 3471 and FOPS 3449. As such all Thwaites cabbed dumpers are approved for use by the UK Major Contractors Group. The Power Swivel skip enables a 90° rotation left and right, allowing the machine easier access to tip loads in restricted areas, giving the operator greater control and reducing risk on site.

Powered by a reliable 55kW turbo diesel engine fitted with a DPF to comply with EU Stage V emission regulations, you get all the power, and torque you need, and with no requirement for AdBlue.

A Spring Applied Hydraulic Release (SAHR) Handbrake, 5" screen displaying 150° around machine visibility, hi-vis steps, LED road lights and twin LED beacons are fitted as standard.

Options include a heated seat, rear wiper and adjustable work lights.

Safe, compliant and competitive.

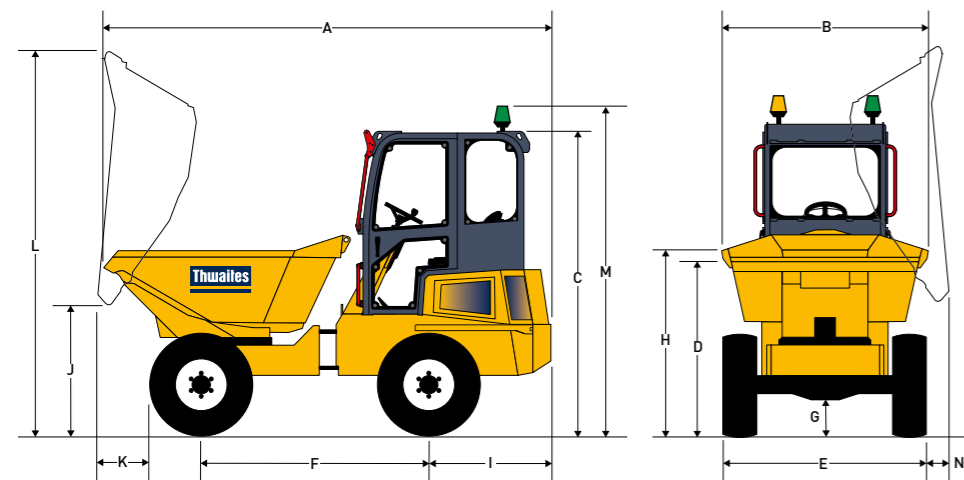

	(mm)		(mm)
A	4815	J	1100
B	2280	K	550
C	3450	L	3694
D	1670	M	3145
E	2240	N	100
F	2480		
G	370		
H	1850		
I	1235		

* Weight and speed figures are estimated and may be subject to change upon final build.

9 Tonne Front Tip Cabbed

Max Safe Load 9000 kg
 Unladen Weight* 5300 kg
 Heaped Load 4600 litres
 Max Speed* 25 km/h

MACH 2490 HYDROSTATIC

FROM AVAILABLE 2024



Key features & benefits

The Thwaites 9 Tonne Front Tip Cabbed, Stage V dumper is manufactured with contractors and hirers in mind – ensuring operator safety, reducing risk on site, and improving performance.

The cab is impact tested to level 2 ROPS 3471 and FOPS 3449. As such all Thwaites cabbed dumpers are approved for use by the UK Major Contractors Group. Front Tip dumpers allow the machine to be easily and safely loaded, with a straightforward tipping action that places the full bucket of spoil exactly where it is required.

Powered by a reliable 55kW turbo diesel engine fitted with a DPF to comply with EU Stage V emission regulations, you get all the power, and torque you need, and with no requirement for AdBlue.

A Spring Applied Hydraulic Release (SAHR) Handbrake, 5" screen displaying 150° around machine visibility, LED road lights and twin LED beacons are all standard equipment.

Options include GPS Speedometer and a heated seat.

Safe, compliant and competitive.

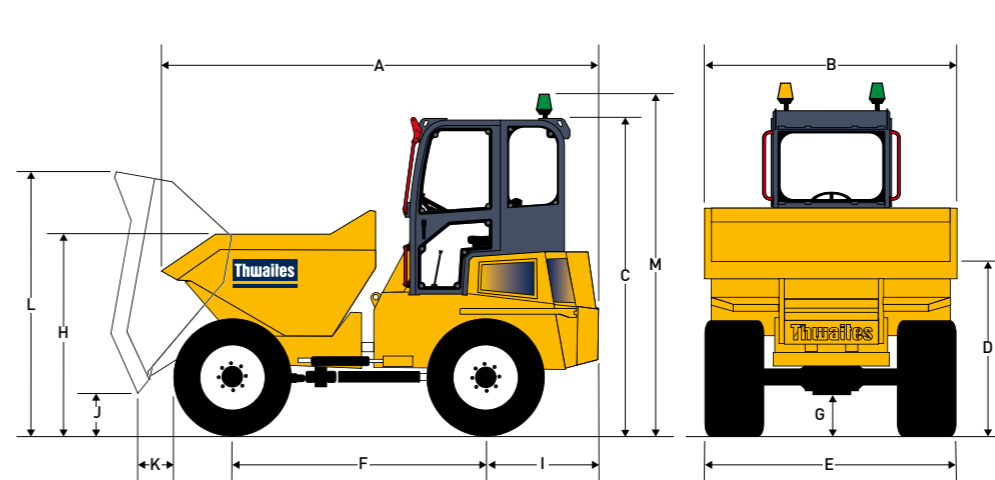

	(mm)		(mm)
A	4670	J	436
B	2485	K	642
C	3285	L	2840
D	1740	M	3588
E	2444		
F	2615		
G	447		
H	1975		
I	1255		

* Weight and speed figures are estimated and may be subject to change upon final build.

Standard & Optional Equipment

Discover which features are standard equipment and which are optional with this quick reference guide.

Model	MACH2001	MACH2002	MACH2003	MACH2076	MACH2071	MACH2077	MACH2081	MACH2080	MACH 3080	MACH2044	MACH 2360	MACH 2362	MACH 2490
Skip Capacity	1 Tonne	1 Tonne	1.5 Tonne	2 Tonne	2 Tonne	2.3 Tonne	3 Tonne	3 Tonne	3 Tonne	4.5 Tonne	6 Tonne	6 Tonne	9 Tonne
Skip Type	High Tip	Power Swivel	Power Swivel	Front Tip	High Swivel	Power Swivel	Front Tip	Power Swivel	Power Swivel	Power Swivel	Front Tip	Power Swivel	Front Tip
Transmission	Hydrostatic	Hydrostatic	Hydrostatic	Hydrostatic	Hydrostatic	Hydrostatic	Hydrostatic	Hydrostatic	Electric	Hydrostatic	Hydrostatic	Hydrostatic	Hydrostatic
Folding ROPS	✓	✓	✓	✓	✓	✓	✓	✓	✓	✓	⊖	⊖	⊖
Cab & Screen Guard	⊖	⊖	⊖	⊖	⊖	⊖	⊖	⊖	⊖	⊖	✓	✓	✓
Amber LED Beacon	✓	✓	✓	✓	✓	✓	✓	✓	✓	✓	✓	✓	✓
Green LED Beacon	✓	✓	✓	✓	✓	✓	✓	✓	✓	✓	✓	✓	✓
Road Lights	✓	✓	✓	✓	✓	✓	✓	✓	✓	✓	✓	✓	✓
Reverse Alarm	✓	✓	✓	✓	✓	✓	✓	✓	✓	✓	✓	✓	✓
White Noise Reverse Alarm	✓	✓	✓	✓	✓	✓	✓	✓	✓	✓	✓	✓	✓
Camera System	⊖	⊖	⊖	✓	✓	✓	✓	✓	✓	✓	✓	✓	✓
GPS Speedometer	⊖	⊖	⊖	⊖	⊖	⊖	⊖	⊖	⊖	✓	✓	✓	✓
Road Mirrors	✓	✓	✓	✓	✓	✓	✓	✓	✓	✓	✓	✓	✓
Wheel Nut Indicator	✓	✓	✓	✓	✓	✓	✓	✓	✓	✓	✓	✓	✓
Sand Tyres	✓	✓	✓	✓	✓	✓	⊖	⊖	⊖	✓	✓	✓	⊖
Towing Bracket	✓	✓	✓	✓	✓	✓	✓	✓	✓	✓	✓	✓	✓
CE Towing Ball	✓	✓	✓	✓	✓	✓	✓	✓	✓	✓	✓	✓	✓
Heated Seat	⊖	⊖	⊖	⊖	⊖	⊖	⊖	⊖	⊖	✓	✓	✓	✓
Air Suspension Seat	⊖	⊖	⊖	⊖	⊖	⊖	⊖	⊖	⊖	⊖	✓	✓	✓
Work Lights	⊖	⊖	⊖	⊖	⊖	⊖	⊖	⊖	⊖	⊖	✓	✓	⊖
Air Conditioning	⊖	⊖	⊖	⊖	⊖	⊖	⊖	⊖	⊖	⊖	✓	✓	✓
Rear Wiper	⊖	⊖	⊖	⊖	⊖	⊖	⊖	⊖	⊖	⊖	✓	✓	✓
USB Socket	⊖	⊖	⊖	⊖	⊖	⊖	⊖	⊖	⊖	⊖	✓	✓	✓
Biological Hydraulic Oil	✓	✓	✓	✓	✓	✓	✓	✓	✓	✓	✓	✓	✓

✓ Standard ✓ Optional ⊖ Not Available

Full spec sheets are available at www.thwaitesdumpers.co.uk

Images in this brochure are representative. Specific details or equipment may vary by country. We reserve the right to change any and all specifications without prior notice. E&OE. 06/2023

Your Official Thwaites Distributor



At BTE Plant Sales we strive to meet your needs on time, every time.

To help us achieve this goal, we have carefully selected Market Leading Brands from the construction industry. The quality and reputation of the manufacturers, coupled with BTE's commitment to five-star service enabling us to offer an unbeatable solution to all your needs.

Manufacturers

Thwaites

Thwaites are our dumper supplier and are market leaders in the range they offer. From 1 tonne to 9 tonne dumpers, Thwaites have mastered high-quality products that keep going from strength to strength.



Kubota offers expertly manufactured mini excavators to have top-class performance and reliability. They have achieved over 25 years as the UK and ROI's Number 1 mini excavator provider which is no mean feat!

MERLO

Merlo offers a versatile range of telehandlers, rotating telehandlers, and tracked carriers. They have an extensive range on offer and have recently entered the electric telehandler market, offering their first fully electric machine.



Bomag provides market-leading compaction equipment. From tandem rollers and pedestrian rollers to compaction plates and tampers, Bomag has a fantastic range to suit an array of construction jobs.

Atlas Copco

Atlas Copco are a hugely diverse manufacturer that provides innovative, mobile, construction, and power equipment. Ranging from air compressors and breakers to lighting towers.



Epiroc

Epiroc specialises in hydraulic attachments to suit excavators from 1 tonne up to 32 tonnes. BTE specialises in hydraulic breakers but we can also provide hydraulic compactors, multi grapples, and concrete busters.

As one of the largest independent plant suppliers in the UK, we pride ourselves on our unrivalled level of customer service. With over 30 years of experience and specialist industry know-how, we can ensure to deliver just the right solution to our customers. However, it is not only products, parts, and service that we take seriously, we also have an extensive range of used equipment to suit all tastes.



For all your plant equipment needs, choose BTE!

Call: 01530 242782 or Email: info@bteplantsales.com



Thwaites Ltd
Leamington Spa
Warwickshire
CV32 7NQ
United Kingdom

Tel: +44 (0)1926 422 471
Fax: +44 (0)1926 337 155

Email: uksales@thwaitesdumpers.co.uk

www.thwaitesdumpers.co.uk



Images in this brochure are representative. Specific details or equipment may vary by country.
We reserve the right to change any and all specifications without prior notice. E&OE. 06/2023

